

THIS DRAWING IS UNPUBLISHED. RELEASED FOR PUBLICATION
 BY AMP INCORPORATED. ALL RIGHTS RESERVED.

| REVISIONS | | | | DATE | DWN | APVD |
|-----------|------|---|-----|--------------------------------------|-----------|------|
| LOC | DIST | P | LTR | DESCRIPTION | | |
| FT | 8 | S | | REDRAWN W/O CHANGE PER EC 0320-98-96 | 20 NOV 97 | - |

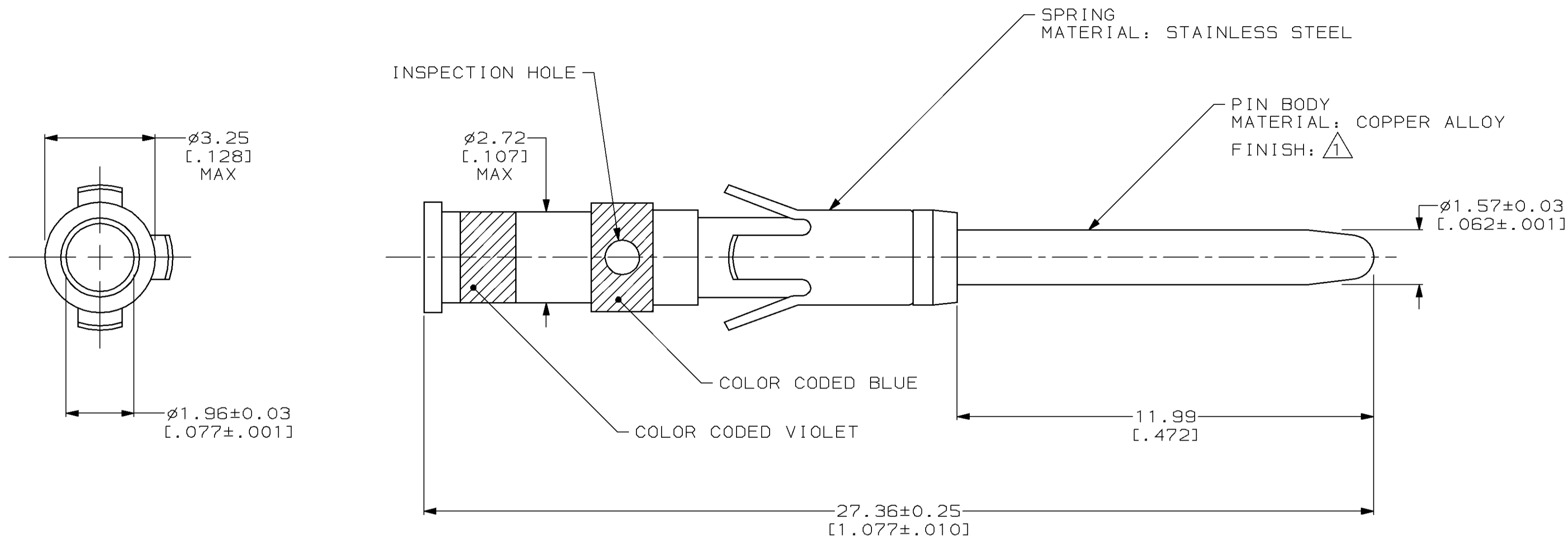

- $\triangle 1$ 0.76 μ m [0.00030] MIN GOLD OVER 1.27 μ m [0.00050] MIN NICKEL.
- $\triangle 2$ WHEN ORDERING CONTACT ASSEMBLY ON TAPE, ORDER BY THE TAPE NUMBER PLUS THE PACKAGING CODE AS FOLLOWS:
 1. FOR USE WITH AMP TAPETRONIC, PNEUMATIC TOOL-
 - A. 1000 PARTS TO A BOX ADD PACKAGING CODE: 1MBOX
 2. FOR USE WITH 4/8 INDENT STRIPPER CRIMPER-
 - A. 1000 PARTS TO A REEL ADD PACKAGING CODE: 1MREEL
 - B. 5000 PARTS TO A REEL ADD PACKAGING CODE: 5MREEL

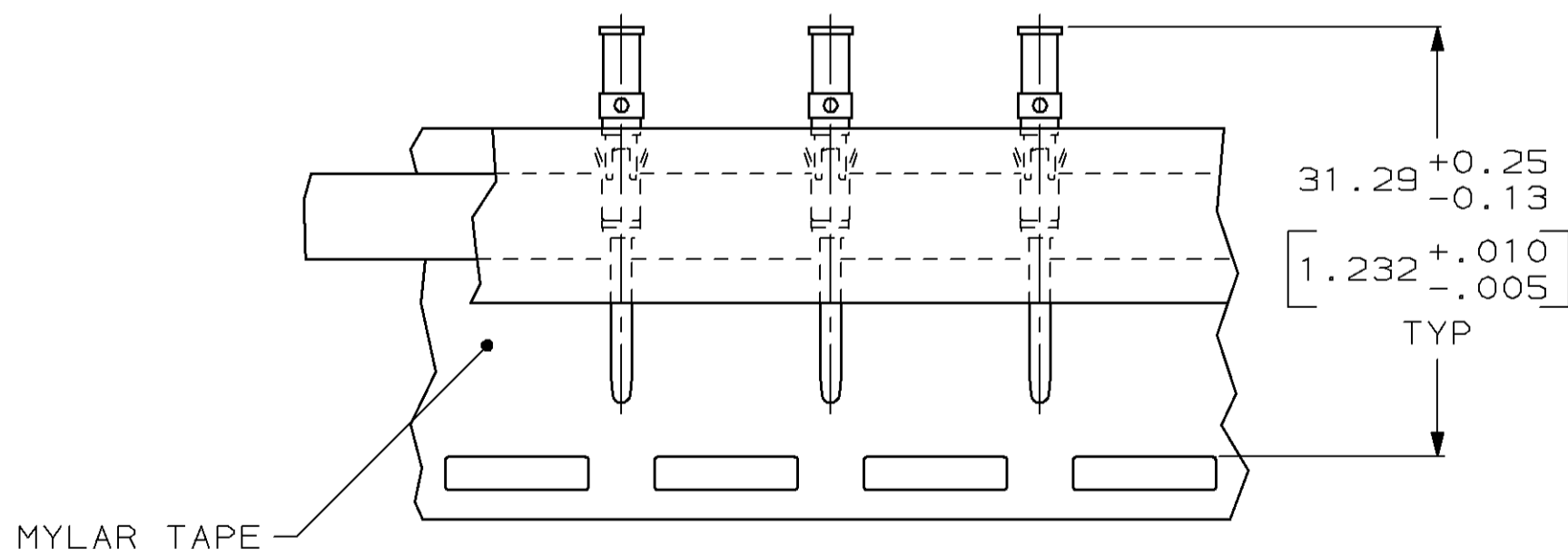

TAPE MTG DETAIL
SCALE 2:1

| | |
|------------------------|-------------|
| TAPE MTD $\triangle 2$ | 201570-2 |
| STANDARD | 201570-1 |
| PACKAGING TYPE | PART NUMBER |

| | | | | | | | | | | | | | |
|---|---------------|------------------------------------|---|---------------|----|-------|---------------|-------|----|-------|----|------------------|--|
| THIS DRAWING IS A CONTROLLED DOCUMENT. | | DWN B. CARBO 20 NOV 97 | AMP Incorporated Harrisburg, PA 17105-3608 | | | | | | | | | | |
| DIMENSIONS: mm [INCHES] | | CHK R. STONE 09 DEC 97 | NAME G. STEINHAUER | | | | | | | | | | |
| TOLERANCES UNLESS OTHERWISE SPECIFIED: | | APVD G. STEINHAUER 16 DEC 97 | PRODUCT SPEC | | | | | | | | | | |
| <table border="0"> <tr><td>0 PLC</td><td>±-</td></tr> <tr><td>1 PLC</td><td>±-</td></tr> <tr><td>2 PLC</td><td>±0.13 [0.005]</td></tr> <tr><td>3 PLC</td><td>±-</td></tr> <tr><td>4 PLC</td><td>±-</td></tr> </table> | | 0 PLC | ±- | 1 PLC | ±- | 2 PLC | ±0.13 [0.005] | 3 PLC | ±- | 4 PLC | ±- | APPLICATION SPEC | |
| 0 PLC | ±- | | | | | | | | | | | | |
| 1 PLC | ±- | | | | | | | | | | | | |
| 2 PLC | ±0.13 [0.005] | | | | | | | | | | | | |
| 3 PLC | ±- | | | | | | | | | | | | |
| 4 PLC | ±- | | | | | | | | | | | | |
| MATERIAL SEE CALLOUTS | | FINISH SEE CALLOUTS | WEIGHT - | RESTRICTED TO | | | | | | | | | |
| CUSTOMER DRAWING | | SCALE 10:1 | SHEET 1 OF 1 | REV 5 | | | | | | | | | |

201570

B

A